

Item Number	Quan	Part Number	Part Name
1	1		Servo/Stepper Motor
2	1		Y-Axis Sensor Rail
3	2		Pin
4	2		M3x20 Socket Head
5	8		M5x15 Socket Head
6	2		Sensor Trigger Block
7	1		Ball Screw Locking Nut
8	2		M3x6 Sey Screw
9	2		M3x8 Socket Head
10	2		M5x10 Socket Head
11	1		Y-Axis Ball Screw
12	4		M6x90 Socket Head
13	1		Base Casting
14	2		Stand Off
15	1		Y Axis Front Hard Stop
16	1		M8x15 Set Screw
17	2		Y Axis Back Hard Stop
18	1		Bearing Spacer
19	6		M4x10 Socket Head
20	1		Flexible Coupler
21	1		Bellow Support Bracket
22	1		Y-Axis Motor Mount Bearing Lock
23	3		M5-5 Set Screw
24	2		7203 Bearing
25	1		Wire Coil
26	4		M6x20 Socket Head
27	1		Y-Axis Motor Mount Cover
28	1		Y-Axis Motor Mount

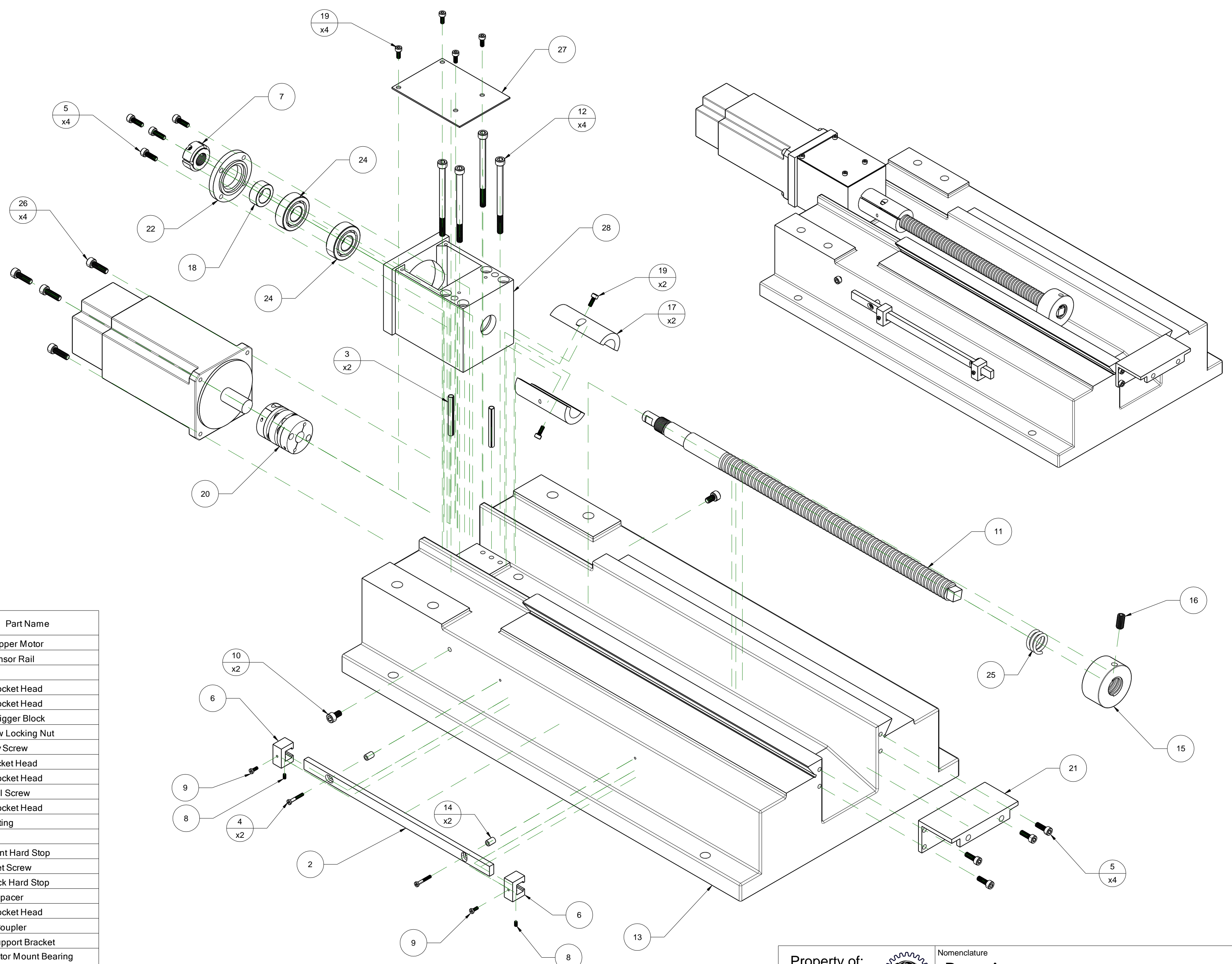

Property of: Novakon International Corp Phone (905) 258-0366 Novakon.net	Nomenclature Base Assy	DATE 21-Oct-2015
	End Item System Pulsar	REV 0
	Sub System	SHEET 1 of 1
	DWG NO.	