

CONECTOR 26 PINOS

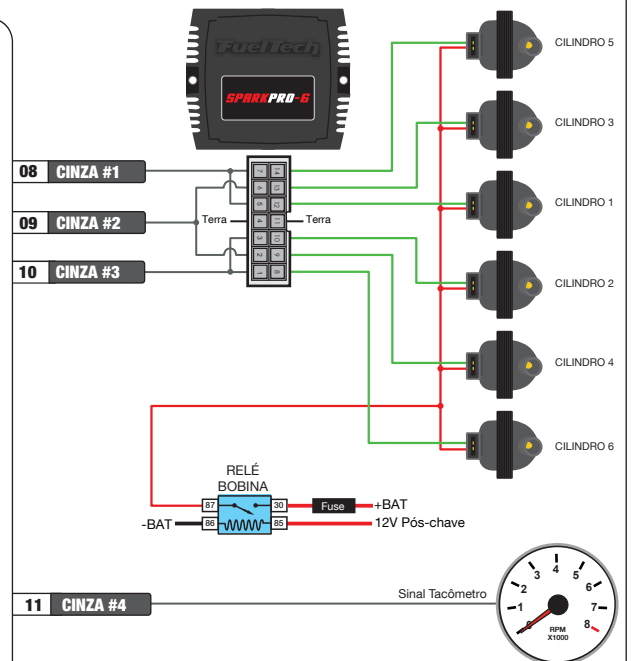

Ordem de ignição (1-4-2-5-3-6)

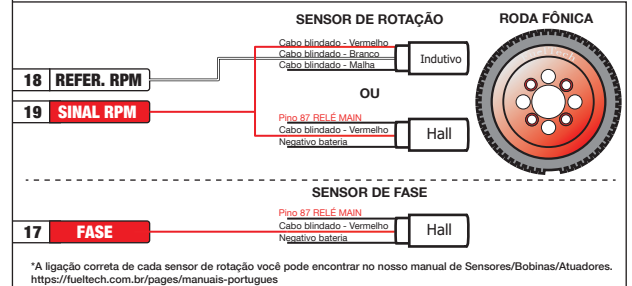

*A ligação correta de cada sensor de rotação você pode encontrar no nosso manual de Sensores/Bobinas/Atuadores.
<https://fueltech.com.br/pages/manuais-portugues>

