

# Flange Binding

by Mary-Jeanine Ibarguen

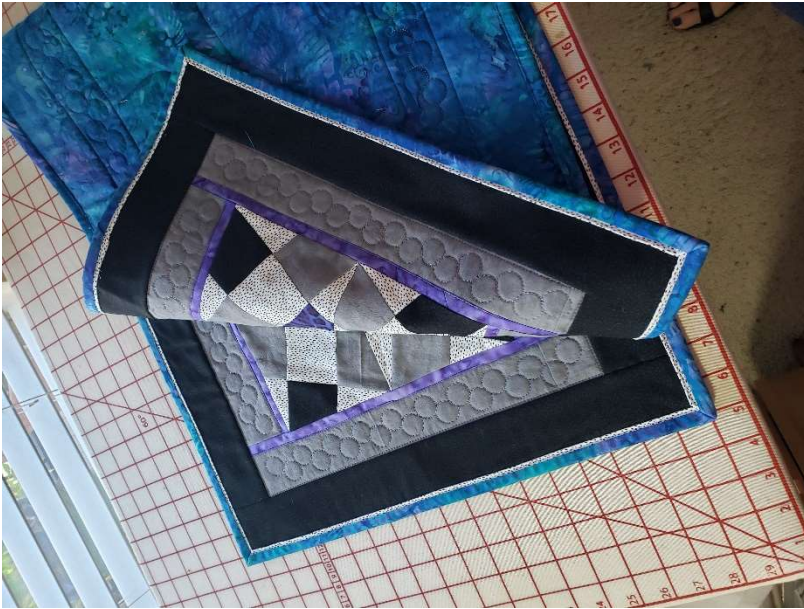

This is my **new favorite way to bind!** I've been putting off learning this new technique...but I'm so glad I decided to take the time. The extra little flange peeking out of the quilt binding really takes your quilt to the next level. I probably won't use the flange technique when I have piecing on the quilt border all the way to the edge, since it will hide just a bit of quilt top and you don't want your beautiful triangle points to go missing. But when your border ends with a single fabric, that would be a great time to try this technique.

I used Missouri Star Quilt Company's technique, here is a great video tutorial: [www.tinyurl.com/FlangeBinding](http://www.tinyurl.com/FlangeBinding) (type those upper case letters just like that)

Jenny (MSQC) likes to cut her regular binding 2.5" wide, but I much prefer 2.25" wide. I like the finished binding to be 1/4" wide to just cover up the last seam. I'm giving you measurements for both.

For 2.5" wide binding, cut your fabric

- Flange fabric: 1.75" wide
- Binding (outside) fabric: 1.5" wide

For 2.25" wide binding, cut your fabric

- Flange fabric: 1.50" wide
- Binding (outside) fabric: 1.25" wide

**Very important:** you will cut from each fabric the full length of binding you need. If your quilt is 50" x 50", you will need 200" of flange fabric and 200" of binding fabric.

Once you sew all the flange strips end to end, and then the binding (outside) strips end to end (all seams on the diagonal), press those diagonal seams open.

Sew those two loooong strips together. One long flange strip to one long binding strip. Press the seam toward the binding (outside) fabric.

**Tip:** You do NOT need to press the binding in half lengthwise. I don't. But you can if you want.

Fold the new binding wrong sides together so the raw edges match up. You'll be sewing the binding to the back of the quilt and then bringing around to the front to sew down by machine.

Sew the binding to the quilt the same way you normally would, mitering the corners the regular way.

When you pull the binding around to the front, match the thread color to the flange fabric, and sew in the ditch on the flange.

I hope you enjoy this new effect as much as I do!!

Please do not make copies w/out permission: [mjibarguen@outlook.com](mailto:mjibarguen@outlook.com) [www.FloridaQuiltNetwork.com](http://www.FloridaQuiltNetwork.com)

# Marble Maze Toy

by *Mary-Jeanine Ibarguen*

Consider this an easy way to keep a child quiet for (hopefully) as long as you need peace. Two rectangles of fabric, a marble and a few minutes of sewing machine time is all you need. Be sure to make the space big enough for the marble to slide through.

## **Fabric needed:**

- 2 rectangles of fun fabric. Let's start with 8" x 5", but really, any size will do.
- 1 glass marble
- Ribbon (optional handle loop)

**Place** the two fabric pieces right sides together.

**Sew** all the way around the perimeter except for a 2" hole to turn. Optionally, add a ribbon loop in the seam now for carrying.

**Tip:** don't make the hole next to a corner. Put it on the side and sew up all four corners. It will be easier to turn and press that hole at the end.

**Clip** the corners and turn the piece right sides out.

**Press** the 'bag' flat, making sure the hole edges are tucked in nicely.

**Insert** the marble into the 'bag'.

**Decide** on your maze pattern. Here are some possibilities:

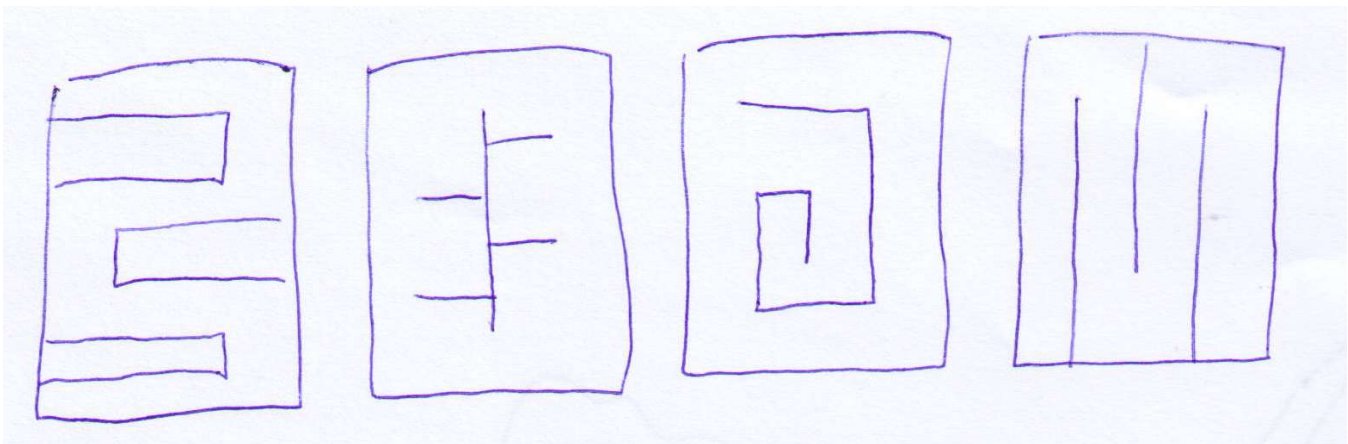

**Sew/Topstitch** the maze lines. Test a space so you know that the marble will fit.

**Tip:** incorporate the topstitching of the bag opening with the design for a professional finish.

# Bird Quilt "No Two Tweets are the Same"

Mary-Jeanine Ibarguen



(front)



(back)

**You can get the free Bird Block Pattern here:**

[tinyurl.com/MJBirdBlock](http://tinyurl.com/MJBirdBlock) (pay attention to upper case)

- This is improvisational piecing, meaning each bird comes out a little different.
- I used mostly scraps for my birds; its fun to match up wing and body fabric.
- Dive into your black & white stash for some fun legs
- To make the Giant Bird on the back, you'll need to do a little math; it depends on your final quilt size, be sure to add extra sky around the edges of the back so its easier to baste the quilt sandwich.
- Notice some birds face left, others face right.
- This modern quilt would look just as lovely without a border.
- My birds are joined in columns. So you don't have to trim all bird blocks to the same size; sort them by width size for columns, and the blocks can be any length. I used spacer sky fabric on top and bottom to offset the birds.

# Storage Pods

Finished Size: 5 ½" x 9 ½" x 5"  
(13.97 cm x 24.13 cm x 12.7 cm)



## Supplies Needed

- 2 Fat Quarters — 18" x 21" (45.72 cm x 53.34 cm)
- 18" x 21" (45.72 cm x 53.34 cm) Cotton batting
- Coordinating thread
- Rotary cutter, mat, and acrylic ruler
- Basic sewing supplies
- Sewing machine
- Iron and pressing surface

## Before You Begin

Read all instructions before beginning project. Do not prewash fabrics. Press fabrics with a dry iron on cotton setting before cutting. Use ¼" (6.35 mm) seam allowance and sew fabrics with right sides together (RST) unless otherwise noted. Press seams in direction of arrows. wof = width of fabric.

Print Pattern at 100% scale. Check measurements after printing to ensure correct size. Cut out Storage Pod Pattern along outside lines.

## Cutting

1. Fold each Fat Quarter RST as shown. Layer the two Fat Quarters on top of each other with edges matching (or even) to cut both pieces at one time. Pin pattern to fabric matching fold with folded edge of fabric. Cut along outside line of pattern.
2. From remaining Lining fabric, cut out one rectangle 2 ¼" x 6" (5.72 cm x 15.24 cm) for Hanging Loop.
3. Use pattern to cut one piece of batting.

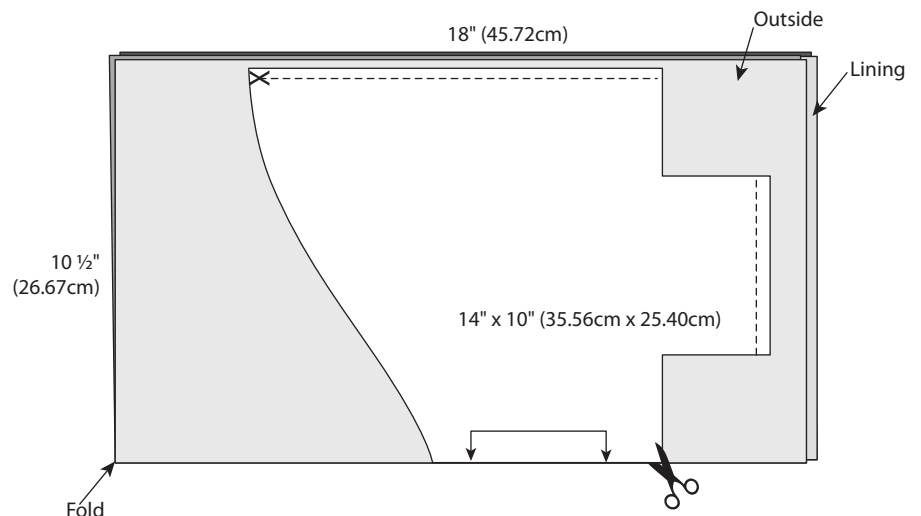

# Assembly

- Layer batting with the **wrong** side of the Outside fabric and align cut edges. Fold RST as shown.

**Tip:** Press the batting and fabric together. The little bit of static helps them stay together during sewing.

- Pin and sew the back and bottom seams RST for the Outside and press. Repeat for the Lining.

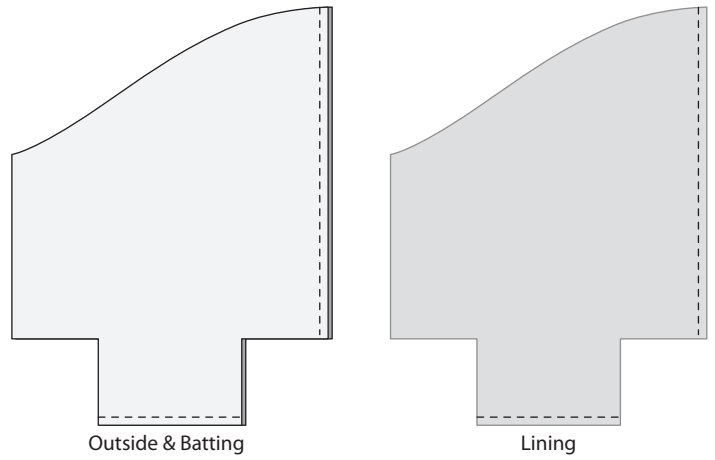

- Box both corners of the Outside bag. Open the bottom cut-out, align back and bottom seams, pin and stitch. Repeat for the other cut-out but align the center front and bottom seams; pin and stitch. Box one corner of the Lining leaving the front open for turning later.

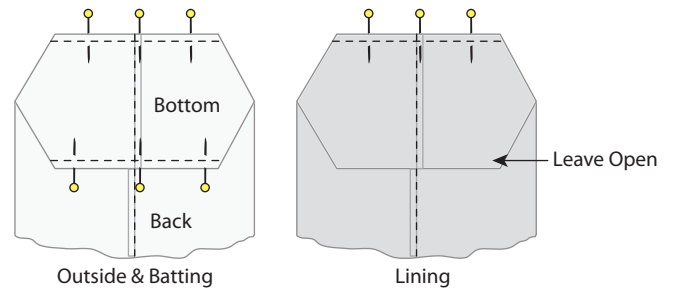

- Fold strip 2 1/4" x 6" (5.72 cm x 15.24 cm) in half lengthwise, **wrong** sides together, and press. Open and re-fold each side to the center and press. Fold as shown and topstitch along both long edges. Fold strips so ends meet to form a loop. Center loop over back seam of Lining. Align at top edge and baste.

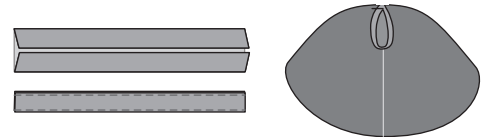

- Turn Lining right side out and insert RST into the Outside. Match back seams and cut edges; pin well. Sew around the top edge.

Turn right side out through opening in Lining. Push out bottom corners and Hanging Loop; press top edge. Topstitch around the top close to the edge. Handstitch opening closed on the Lining.

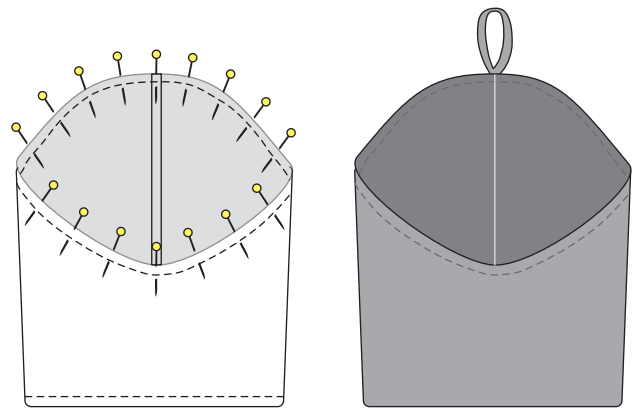

# Finished Care Instructions

Machine wash in cold water, with mild detergent on gentle cycle. Lay flat to dry or tumble dry low; press.

**Template (100% Scale)**

Print and tape together, overlapping where indicated.

Scale:  
1 square =  
1" x 1"

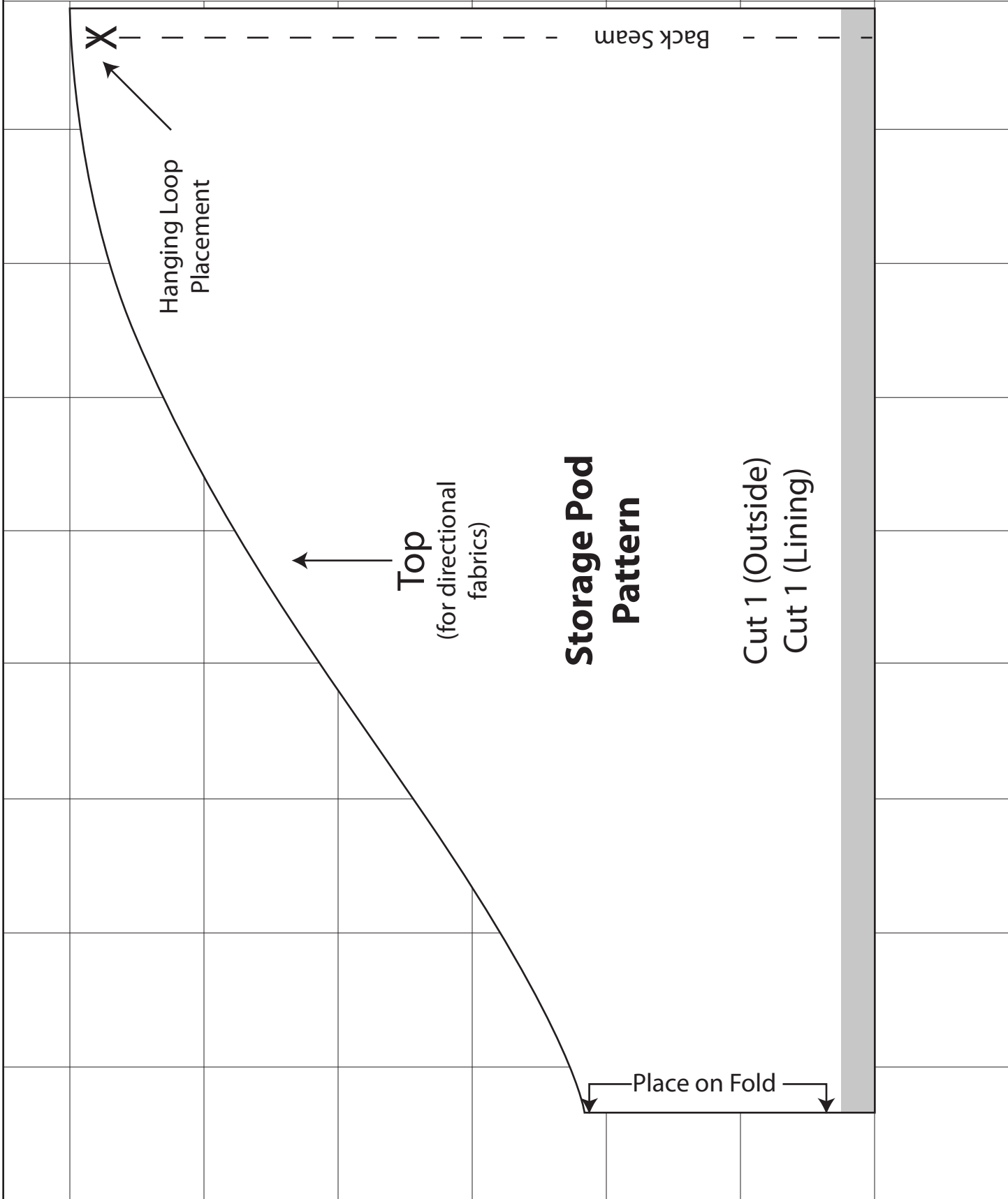

**Template (100% Scale)**

Print and tape together, overlapping where indicated.

Scale:  
1 square =  
1" x 1"

