

OVERLAND MAILBOX INSTALLATION

TOOLS & SUPPLIES

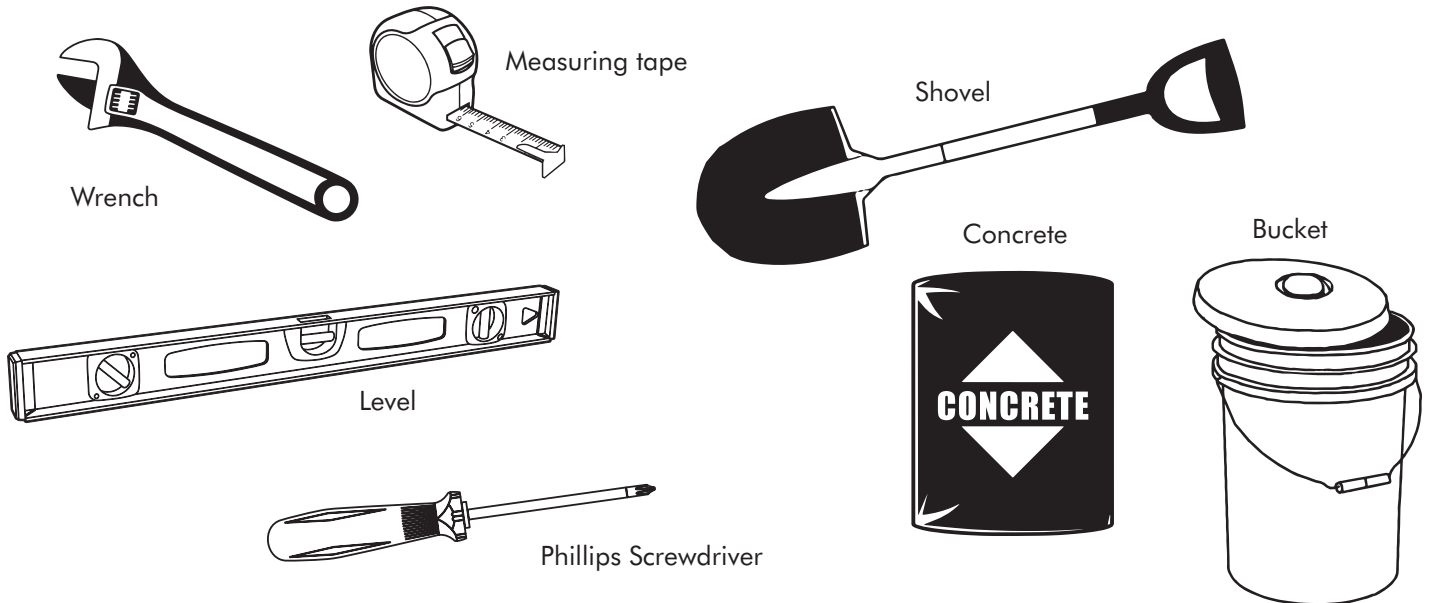
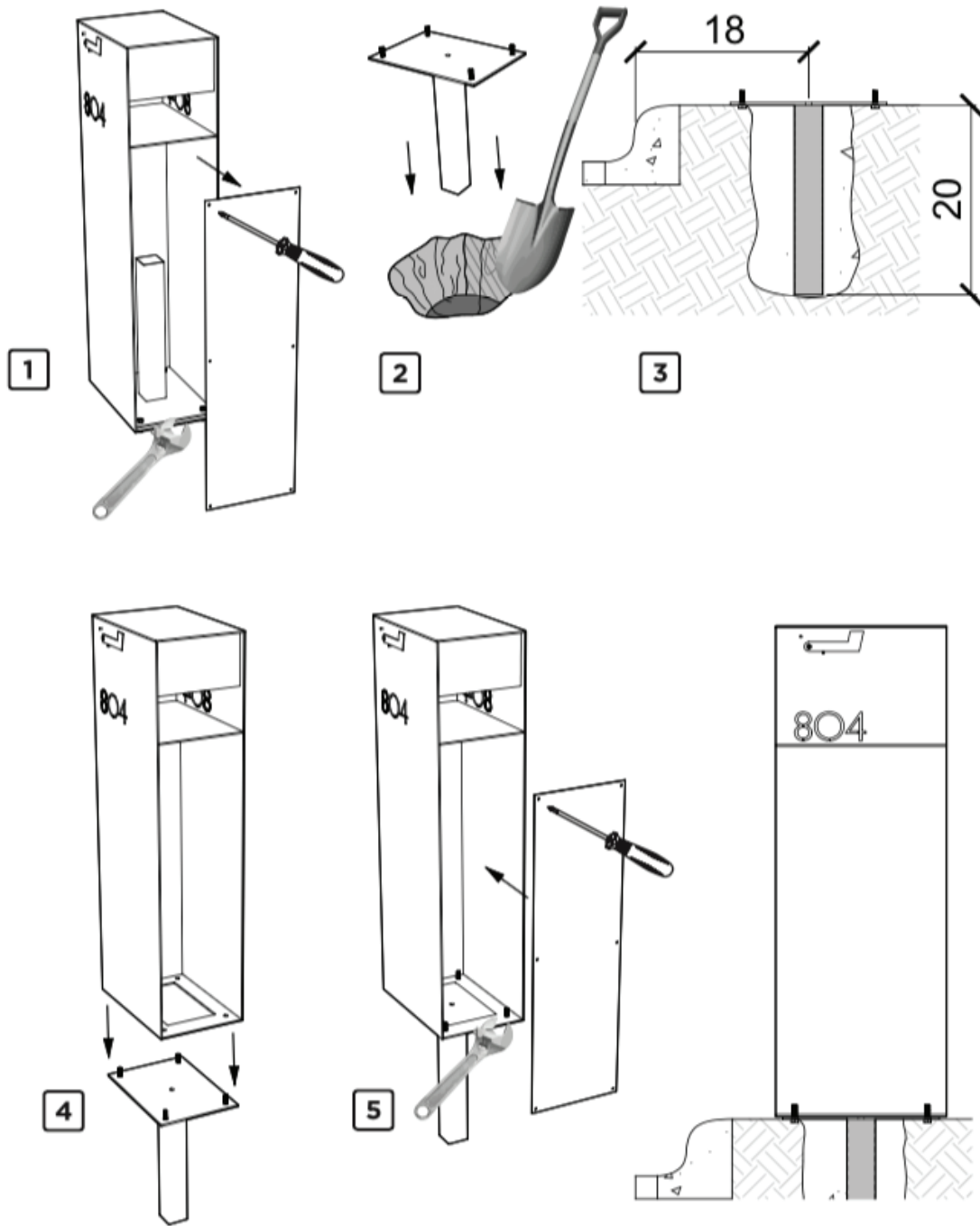

INSTRUCTIONS

1. Remove the 6 screws from the back with the screwdriver to remove the post that is inside. Unscrew the nuts at the bottom to remove the post.
2. Locate the hole location around 18" back from the curb. Dig a hole 12" diameter and a little over 20" deep.
3. Mix concrete per instructions on the bag. Pour the concrete into your hole and set the base post at grade. Use your level to check that the baseplate is sitting level. Let the concrete cure (usually a couple hours).
4. Once post is set, set the mailbox on top of the base plate. Use the included bolts to secure the mailbox. Tighten the bolts with your wrench. Check that the mailbox is level. If not loosen bolts and shim as necessary.
5. Use the 6 screws to re-install the back panel and enjoy!



Per U.S. Postal Service Standard – Mailboxes, Curbside, paragraph 3.12.1

Assembly and Installation: A complete set of instructions for assembling and mounting the mailbox shall be furnished with each unit. The instructions must include the following conspicuous message:

PURCHASER IS REQUIRED TO CONTACT THE LOCAL POST OFFICE BEFORE INSTALLING THE MAILBOX TO ENSURE ITS CORRECT PLACEMENT AND HEIGHT AT THE STREET. GENERALLY, MAILBOXES ARE INSTALLED AT A HEIGHT OF 41 - 45 in. FROM THE ROAD SURFACE TO INSIDE FLOOR OF THE MAILBOX OR POINT OF MAIL ENTRY (LOCKED DESIGNS) AND ARE SET BACK 6 - 8 in. FROM FRONT FACE OF CURB OR ROAD EDGE TO THE MAILBOX DOOR.

Have questions? Please contact us at sales@boldmfg.com